



DIAMOND
AUDIO

DPRS10

10" Low Profile
Amplified Subwoofer

USER MANUAL

Thank you for purchasing a Diamond Audio product for your car audio system. You have chosen Diamond Audio because you deserve the best!

Diamond Audio products are designed and engineered to the highest quality standards in the industry to create the ultimate listening experience. For optimal performance of this product, it is highly recommended that you have it installed by an authorized Diamond Audio dealer.

Please contact your local authorized Diamond Audio dealer if you have questions regarding the instructions in this manual or the product's operational capabilities. If you require additional assistance, please contact the Diamond Audio Technical Support Department during business hours (PST) at 213-212-3187.

Specifications

MODEL:	DPRS10
Power	120 WRMS/300 WMAX
THD	<0.5%
Signal-to-noise ratio	>90dB
Frequency response	20Hz - 180Hz
Input sensitivity, high level	1.0V
Input sensitivity, low level	300V
Low Pass Filter	50Hz - 180Hz
Bass Boost	0 to + 12dB
Subsonic Filter	20Hz
Fuse rating	20A
Subwoofer	10 inch , 4 ohm
Dimensions(L x W x H) inches/mm	12.2"(310) x 9"(230)x 3"(78)

All specifications subject to change without notice.

Panel controls and features

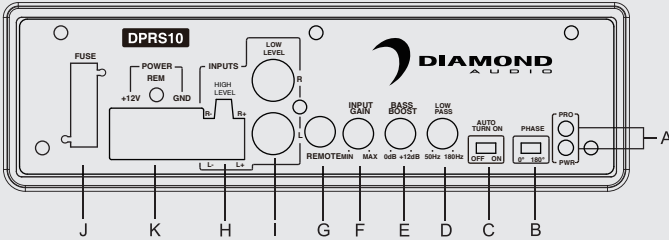

A. POWER STATUS LED

This bi-color LED glows green when power is on and no problems are present. If one of the protection circuits comes on, it will change to red.

B. PHASE SHIFT

Use this switch to help compensate for time alignment problems in the system. Such problems usually result from having the subwoofer at a different distance from the listener than the other speakers in the system.

C. AUTO POWER ON

The AUTO POWER ON(ON/OFF) is for high level (speaker-level) connections. When the switch is in the “ON” position, the subwoofer AUTO POWER ON when there is signal input. If the amplifier detected no signal input, the amplifier will auto turn off. If you prefer to use the remote turn on/off connection, the switch is in the OFF position.

Note: Please connect the remote terminal to the remote output of head unit as Fig.4. If you hear the unit turn ON/OFF POP noise from the subwoofer.

D. LOW PASS FILTER

This control permits you define the frequency range you want the subwoofer amplifier to receive. The subwoofer will reproduce all sound BELOW the frequency you set.

Note: The Low Pass filter frequency may be off some as there is a 20% tolerance in the filters.

E. BASS BOOST

The BASS BOOST feature will increase the sound level in the bass frequencies.

F. INPUT GAIN CONTROL

After you have installed your system, turn this control to minimum.

Turn the head unit on (and the subwoofer will turn on via the remote connection). Turn the head unit volume to about 2/3 full level.

Slowly turn up the subwoofer input gain control until you hear a small amount of distortion. Then reduce the level until the distortion is completely gone. Level the control at this setting.

G. REMOTE LEVEL CONTROL PORT

Attach the included remote level control to control the volume level of the subwoofer independently.

H. HIGH LEVEL (speaker level) INPUTS

If your head unit does not have RCA outputs you can use the speaker outputs for the audio source for the subwoofer. Use the supplied cable and wire harness and connect the outputs properly as shown in the connection diagram in this manual.

I. LOW LEVEL RCA INPUTS

Low level inputs are the recommended way to introduce the audio signal to the subwoofer if RCA outputs are present on your head unit or other signal source (such as a sound processor).

J. FUSE

Do not use a fuse with a different value and NEVER replace the fuse with a wire or coin.

K. POWER INPUT TERMINAL

Power, Ground, and Remote Turn on Connection

Low Level Input Wiring

Low-level (RCA) input wiring is preferred for best audio performance. Most trunk or hatchback installations will require a 15-20 feet RCA cable, while pickup trucks and under-seat installations will require a 6-12 feet RCA cable. Always use a high quality cable.

NOTE: Do not connect BOTH the high level and low level inputs from your receiver to your amplifier at the same time!

Fig.1

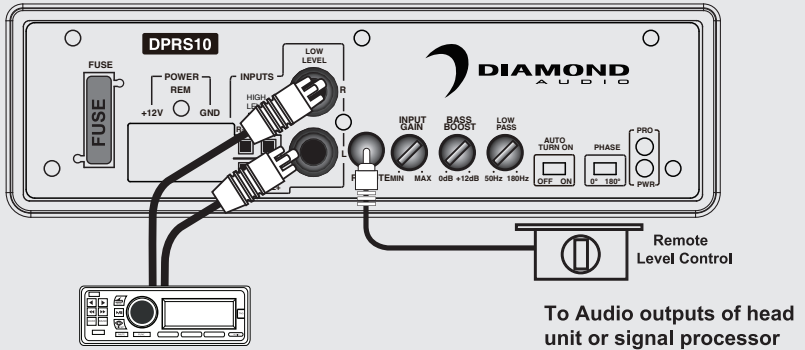

High Level Input Wiring

The high level input(s) should only be used when your receiver lacks RCA outputs. If the RCA outputs are not present, connect the speaker outputs from the receiver to the high level input connector of the amplifier. Be sure to observe polarity to avoid audio phase problems.

NOTE: Do not connect BOTH the high level and low level inputs from your receiver to your amplifier at the same time!

Fig.2

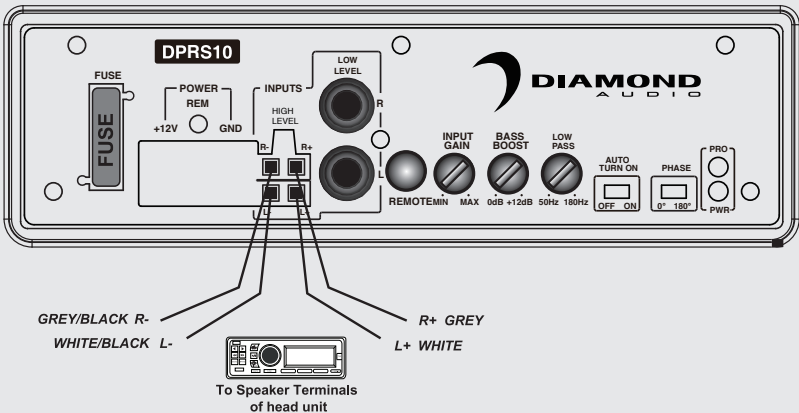

Power Connections

Connect the ground terminal to the closest point on the chassis of the vehicle. Keep this ground wire to less than 39" (100 cm) in length. Use 8 gauge (or heavier) wire.

Connect the remote terminal to the remote output of head unit using 16 gauge (or heavier) wire.

Connect a fuse holder (with a 25A fuse) within 18" (45 cm) of the car battery, and run 8 gauge (or heavier) cable from this fuse to the amplifier location. Then connect the fuse holder to the "BATT+" (+12V) connection on the subwoofer rear panel.

Fig.3

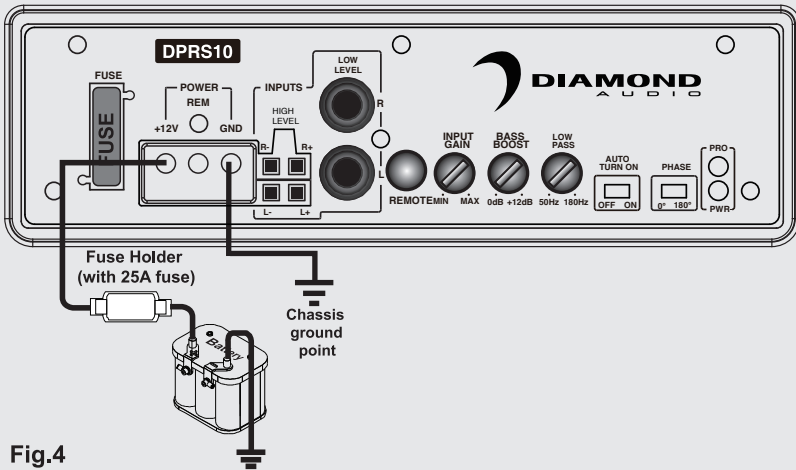
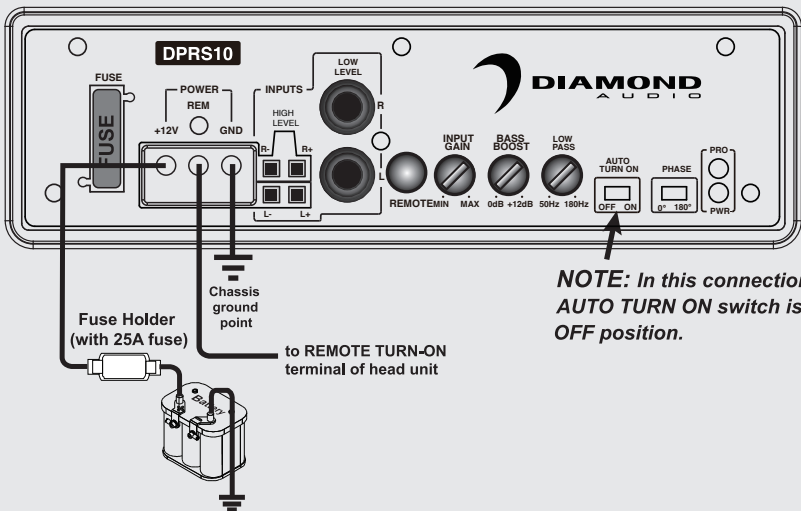
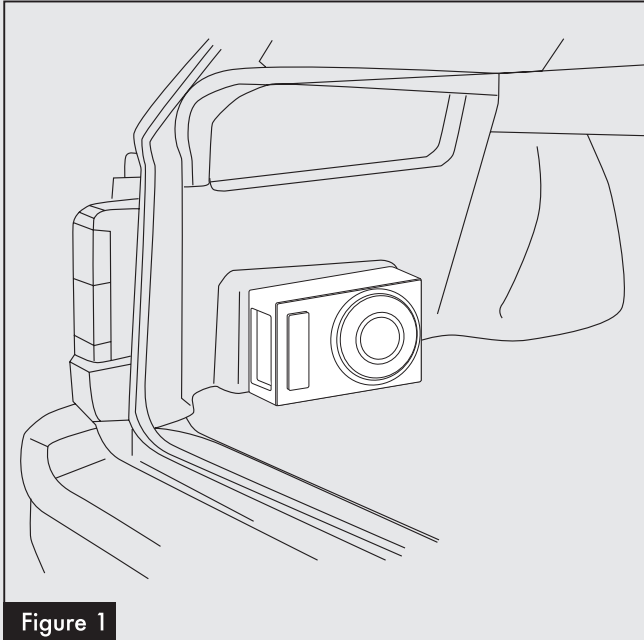

Fig.4



We include installation brackets to ensure the subwoofer remains securely mounted. Two types of installation are possible.

In the trunk



- 1 - Rear seats must be positioned in their normal fixed position.
- 2 - Decide the best location possible that suits your automobile and space available. The best and most secure location for optimum sound quality is behind the rear seats, in the trunk floor (see Figure 1).
- 3 - Ensure the area for subwoofer location is clean and tidy. Any loose objects must be removed, as they could knock and damage the subwoofer.
- 4 - Once the location has been decided, Mark the screw hole positions for the mounting brackets
- 5 - Drill holes for the mounting brackets.
- 6 - Secure the brackets to the enclosure using the M6x8mm screws (Figures 2 & 3)
- 7 - Position the enclosure so that the brackets align with your pre-drilled holes and secure with the M4x25mm screws. (Figure 4)
- 8 - Make sure the enclosure is tightly secured to the vehicle.



CAUTION!! Make sure to not drill or screw into the vehicles gas tank!!!



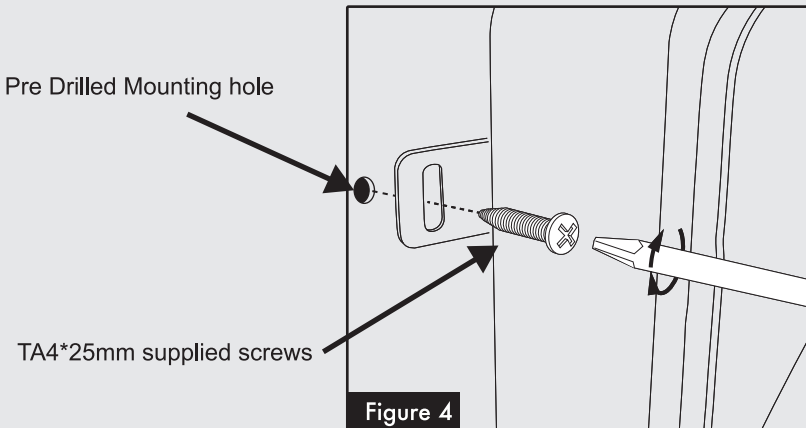
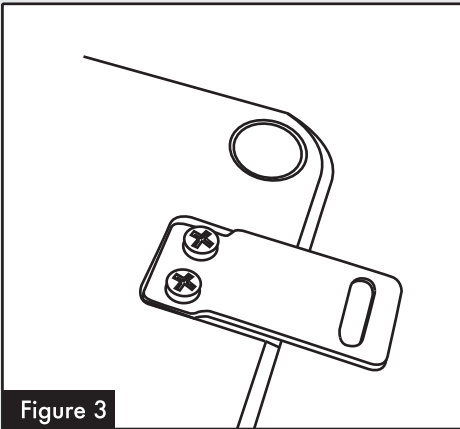
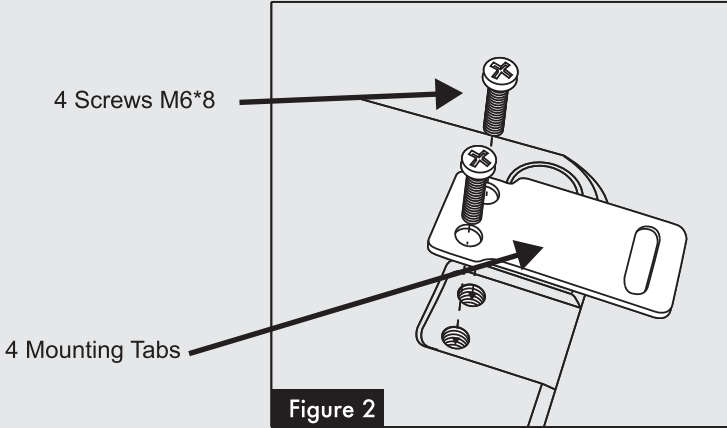

Under a seat

- 1 - The seat must be positioned in its normal fixed position.
- 2 - Decide the best location possible that suits your automobile and space available.
The best and most secure location for optimum sound quality is behind the rear seats, in the trunk floor (see Figure 1).
- 3 - Ensure the area for subwoofer location is clean and tidy. Any loose objects must be removed.
- 4 - Once the location has been decided, Mark the screw hole positions for the mounting brackets
- 5 - Drill holes for the mounting brackets.
- 6 - Secure the brackets to the enclosure using the M6x8mm screws (Figures 2 & 3)
- 7 - Position the enclosure so that the brackets align with your pre-drilled holes and secure with the M4x25mm screws. (Figure 4)
- 8 - Make sure the enclosure is tightly secured to the vehicle.



CAUTION!! Make sure to not drill or screw into the vehicles gas tank!!!



Under a seat

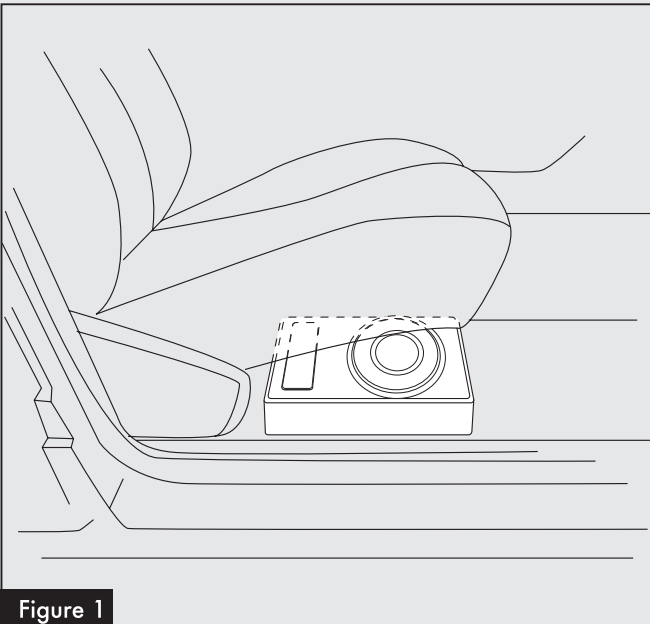
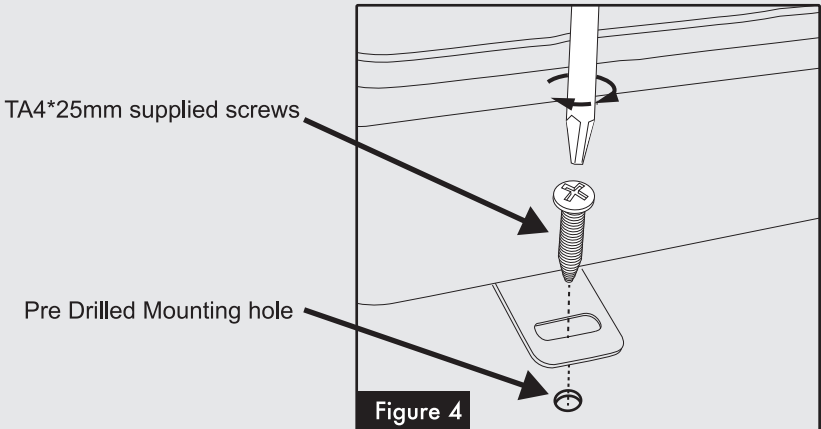
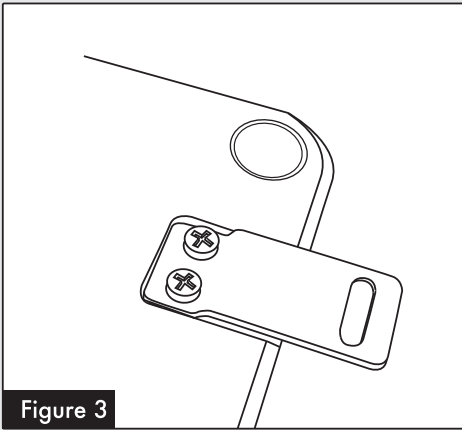
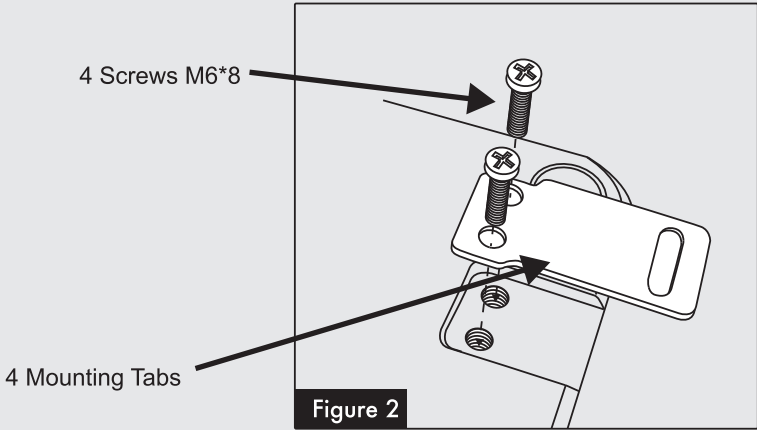

Figure 1



If you experience operation or performance problems with this product, compare your installation with the electrical wiring diagram on the previous pages. If problems persist, read the following troubleshooting tips which may help eliminate the problems.

SYMPTOM	POSSIBLE REMEDY
Amplifier will not power up.	<p>Check to make sure you have a good ground connection.</p> <p>Check that the Remote Input (Turn-On) has at least 5VDC.</p> <p>Check that there is battery power on the (+) terminal.</p> <p>Check that there is at least 12v.</p> <p>Check all fuse, replace if necessary.</p> <p>Make sure that the Protection LED is not illuminated. If it is lit, shut off the amplifier briefly, and then repower it.</p>
Protection LED comes on when amplifier is powered up	<p>Check for short circuits on speaker leads.</p> <p>Turn down the volume control on the head unit to prevent overdriving.</p> <p>Remote speaker leads, and reset the amplifier. If the Protection LED still comes on, then the amplifier is faulty and needs servicing.</p>
No output.	<p>Check that all fuses are OK.</p> <p>Check that unit is properly grounded.</p> <p>Check that the Remote Input (Turn-On) has at least 5VDC.</p> <p>Check that the RCA audio cables are plugged into the proper inputs.</p> <p>Check all speaker wiring.</p>
Low output.	<p>Reset the Level Control.</p> <p>Check the Crossover Control settings.</p>
High hiss in the sound.	<p>Disconnect all RCA inputs to the power sub's control panel. If the hiss disappears, then plug in the component driving the amplifier and unplug its inputs. If the hiss disappears at this point, go on until the faulty/noisy component is found.</p> <p>It is best to set the amplifier's input level control as low as possible. The best subjective signal-to-noise ratio is achieved in this manner. Try to set the head unit as high as possible (without distortion) and the amp input level as low as possible.</p>
Squealing noise is present.	<p>Check for improperly grounded RCA interconnects.</p>
Distorted sound.	<p>Check that the Input Level Control is set to match the signal level of the head unit. Always try to set the Input Level as low possible.</p> <p>Check that all crossover frequencies are properly set.</p> <p>Check for short circuits on the speaker leads.</p>
Amplifier gets very hot.	<p>Check that the minimum speaker impedance for the amp model is correct.</p> <p>Check that there is good air circulation around the amp. In some applications, it may be necessary to add an external cooling fan.</p>
Engine noise (static type)	<p>This is usually caused by poor quality RCA cables, which can pick up radiated noise. Use only the best quality cables, and route them away from power cables.</p>
Engine noise (alternator whine)	<p>Check that the RCA grounds are not shorted to the vehicle chassis</p> <p>Check that the head unit is properly grounded.</p>

WARRANTY

Diamond Audio Technologies (DAT), a division of CV & DA Holdings Incorporated, warrants this product to be free from defects in material and workmanship for a period of one (1) year from the original date of purchase, provided it was purchased from an authorized DAT retailer within the United States. Product warranty period starts at the date of purchase or one year past the manufacture date whichever is first. However, upon purchase and completion of the on-line registration and installation by an authorized DAT dealer, warranty period will be extended to two (2) years. This warranty extension offer will only be recognized upon completion of the on-line registration of your product within thirty (30) days of the date of purchase.

THIS WARRANTY IS NOT TRANSFERABLE AND APPLIES ONLY TO THE ORIGINAL PURCHASER OF THIS PRODUCT IN ITS ORIGINAL INSTALLATION. Original purchaser must reside in the United States and be able to provide proof of purchase and installation with the sales receipt and completion of online registration from the authorized DAT retailer that sold and installed the product.

Should a manufacturing defect occur during above said warranty period, DAT will replace or repair the defective product with a product of the same or equivalent value and performance, at DAT's discretion.

Damage or failure caused by any of the following is not covered under this warranty policy: negligence, improper use, abuse, product modification, unauthorized repair attempts, accident, acts of God, misrepresentations by DAT retailers, and improper/inadequate packaging during return shipping.

Warranty is void if serial numbers have been removed, altered or defaced.

HOW TO OBTAIN WARRANTY SERVICE

In the event a DAT product should require service, you should visit the authorized DAT retailer you purchased the product from and they can expedite your claim. All claims must fall into the guidelines listed above and be accompanied by a copy of the original sales and installation receipt from that authorized DAT retailer.

Product returned for warranty service must be freight-prepaid, properly packaged and clearly marked with the Return Authorization (RA) number issued by DAT. Any product returned to DAT that is improperly packaged, does not have a RA number clearly marked on the package, or never received a RA number, may be refused upon delivery. DAT does not assume responsibility for lost or misdirected product.

Repair or replacement under this warranty is the exclusive remedy of the consumer. DAT shall not be liable for any incidental or consequential damages for breach of any expressed or implied warranty on this product. Some states do not allow the exclusion or limitation of incidental or consequential damages, or allow limitations on how long an implied warranty lasts, so the above limitations or exclusions may not apply to you. This warranty gives you specific legal rights and you may also have other rights that may vary from state to state.

Customers outside the United States should contact their local sales office to obtain information on pricing, exchange unit availability, instructions, service and warranty/non-warranty replacement or repair.

Diamond Audio Technologies

3761 S. Hill Street

LOS ANGELES, CA 90007

Tel: 213-261-4161

Fax: 213-947-4767

Web: diamondaudio.com

Service/Tech Support:

213-261-4161

Tech Support Email

helpdesk@dat-cvm.com



DIAMOND

©2021 Diamond Audio. All rights reserved.
(a division of CV & DA Holdings, Inc.)